



雅仪科技——【嵌入式智能互联设备】软硬件方案供应商。  
专注【远程网络视频监控系统】研发设计。更多资讯浏览：  
<http://www.travellinux.com> 获取。



Hi3556 V100 HD Mobile Camera SoC

## Brief Data Sheet

Issue 01

Date 2017-01-10

**Copyright © HiSilicon Technologies Co., Ltd. 2016. All rights reserved.**

No part of this document may be reproduced or transmitted in any form or by any means without prior written consent of HiSilicon Technologies Co., Ltd.

### **Trademarks and Permissions**



**HISILICON**, and other HiSilicon icons are trademarks of HiSilicon Technologies Co., Ltd.

All other trademarks and trade names mentioned in this document are the property of their respective holders.

### **Notice**

The purchased products, services and features are stipulated by the contract made between HiSilicon and the customer. All or part of the products, services and features described in this document may not be within the purchase scope or the usage scope. Unless otherwise specified in the contract, all statements, information, and recommendations in this document are provided "AS IS" without warranties, guarantees or representations of any kind, either express or implied.

The information in this document is subject to change without notice. Every effort has been made in the preparation of this document to ensure accuracy of the contents, but all statements, information, and recommendations in this document do not constitute a warranty of any kind, express or implied.

## **HiSilicon Technologies Co., Ltd.**

Address: Huawei Industrial Base  
Bantian, Longgang  
Shenzhen 518129  
People's Republic of China

Website: <http://www.hisilicon.com>

Email: [support@hisilicon.com](mailto:support@hisilicon.com)



# Hi3556 V100 HD Mobile Camera SoC

## Introduction

Hi3556 V100 is a new-generation MobileCam™ intelligent video processor provided by HiSilicon, a leading supplier in the global ultra-HD video technologies. The Hi3556 V100 processor is launched for the consumer drone camera, motion DV, 3D/VR camera, and high-end EDR product fields.

- Hi3556 V100 uses the HiSilicon fifth-generation Hi-Lark high-performance video encoder, which supports the 1080P60 and 1440P30 high-quality and low-bit-rate video recording.
- Hi3556 V100 uses the HiSilicon fourth-generation Hi-ISP high-performance graphics processor and adopts the latest 3A, 3DNR, and HDR technologies to achieve professional picture effect.
- Hi3556 V100 supports dual sensor inputs and maximum 16-megapixel and 8-megapixel video processing to flexibly support the service scenarios that required dual-channel recording, such as the 3D/VR camera. Hi3556 V100 integrates high-speed transfer and storage USB 3.0 and PCIe 2.0 interfaces that transfer and store 1080P30 RAW data to achieve the effect of a professional camera.
- Hi3556 V100 integrates the high-performance dual-core CPU (A17+A7). Apart from the video encoding and ISP processing functions, Hi3556 V100 also supports intelligent functions, such as EIS and optical flow hovering. Hi3556 V100 adopts the 28 nm HPC+ advanced manufacturing process and the 10 mm x 10 mm (0.39 in. x 0.39 in.) FC-CSP package. These features enable Hi3556 V100 to continuously lead the industry in high picture quality, low power consumption, and miniaturization.

## Key Specifications

- **1080P60/1440P30 Encoding**  
1080P60+800 x 480@30 fps or 1440P30+720P30+800 x 480@60 fps H.265 encoding
- **Dual-Sensor Inputs**  
Dual-sensor inputs and dual-channel ISP processing and recording
- **6-DOF DIS**
- **High-Speed Memory Interfaces**  
USB 3.0 or PCIe 2.0 high-speed interface
- **RAW Video Output**  
Professional 1080p@30 fps video RAW output
- **Low Power Consumption**  
Less than 1 W typical power consumption in 1440P30+720P30+ 800 x 480@60 fps H.265 encoding scenario
- **Miniaturization Package**  
10 mm x 10 mm (0.39 in. x 0.39 in.) package

## Application Scenario

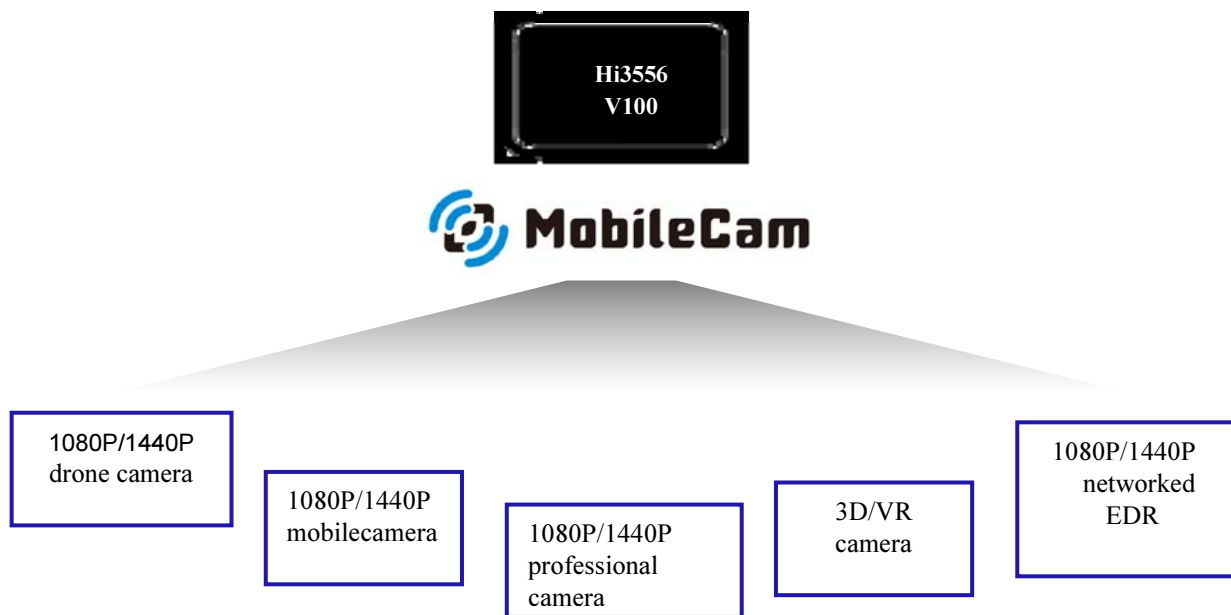



# Hi3556 V100 HD Mobile Camera SoC

## Major Specifications

### Processor Core

- 1.25 GHz A17 core, supporting 32 KB I-cache, 32 KB D-cache, and 256 KB L2 cache
- 800 MHz A7 core, supporting 32 KB I-cache, 32 KB D-cache, and 128 KB L2 cache
- Neon acceleration, integrated FPU
- Linux+Huawei LiteOS dual-system heterogeneous architecture

### Video Encoding

- H.264 BP/MP/HP
- H.265 Main Profile
- I/P/B frame H.264/H.265 encoding, supporting the dual-P-frame reference mode
- MJPEG/JPEG Baseline encoding

### Video Encoding Performance

- Maximum 16-megapixel (4608 x 3456) resolution for H.264/H.265 encoding
- H.264/H.265 multi-stream real-time encoding capability
  - 1080P60+800 x 480@30 fps
  - 1440P30+720P30+800 x 480@60 fps
- Maximum 16-megapixel@15 fps JPEG snapshot performance
- CBR, VBR, FIXQP, AVBR, and QPMAP modes
- Maximum 100 Mbit/s output bit rate
- Encoding of eight ROIs

### Intelligent Video Analysis

- Integrated intelligent analysis acceleration engine, which allows customers to develop intelligent applications targeted for the mobile camera product, such as optical flow hovering and target tracking

### Video and Graphics Processing

- 3DNR, image enhancement, and DCI
- Anti-flicker for output videos and graphics
- 1/30x to 16x video scaling
- Horizontal seamless stitching of 2-channel videos
- 1/2x to 2x graphics scaling
- OSD overlaying of eight regions before encoding
- Video graphics overlaying of two layers (video layer and graphics layer)

### ISP

- 2-channel independent ISP processing
- Adjustable 3A functions (AE, AWB, and AF)
- FPN removal
- Highlight suppression, backlight compensation, gamma correction, and color enhancement
- DPC, NR, and DIS
- Anti-fog
- LDC and fisheye correction
- Picture rotation by 90° or 270°
- Picture mirror and flip
- Sensor built-in WDR, 4F/3F/2F frame-based/line-based

WDR, and local tone mapping. The second channel of ISP processing supports only sensor built-in WDR, 2F frame-based/line-based WDR, and local tone mapping.

- ISP tuning tools for the PC

### Audio Encoding/Decoding

- Voice encoding/decoding complying with multiple protocols by using software
- MP3 or AAC audio encoding format
- Audio 3A functions (AEC, ANR, and ALC)

### Security Engine

- AES, DES, and 3DES encryption and decryption algorithms implemented by using hardware
- RSA1024/2048/4096 signature verification algorithm implemented by using hardware
- Hash-SHA1/256 and HMAC\_SHA1/256 tamper proofing algorithms implemented by using hardware
- Integrated 512-bit OTP storage space and hardware random number generator

### Video Interfaces

- VI Interfaces
  - Two sensor inputs. The maximum resolution for the main channel is 16 megapixels (4608 x 3456), and the maximum resolution for the second input is 8 megapixels (4096 x 2160).
  - 8-/10-/12-/14-bit RGB Bayer DC timing VI, at most 150 MHz clock frequency
  - BT.601, BT.656, and BT.1120 VI interfaces
  - Maximum 12-lane MIPI/LVDS/sub-LVDS/HiSPi interface for the main channel
  - Maximum 4-lane MIPI/LVDS/sub-LVDS/HiSPi interface for the second sensor interface
  - Compatibility with mainstream HD CMOS sensors provided by Sony, Aptina, OmniVision, and Panasonic
  - Compatibility with the electrical specifications of parallel and differential interfaces of various sensors
  - Programmable sensor clock output
- VO interfaces
  - One PAL/NTSC output for automatic load detection
  - One BT.1120/BT.656 VO interface for connecting to an external HDMI or SDI, 1080p@60 fps output at most
  - LCD output

### Audio Interfaces

- Integrated audio codec supporting 16-bit audio inputs and outputs
- I<sup>2</sup>S interface for connecting to the external audio codec
- Dual-channel differential MIC inputs for reducing background noises

### Peripheral Interfaces

- POR
- External reset input
- Internal RTC
- Integrated 3-channel LSADC



# Hi3556 V100 HD Mobile Camera SoC

- Five UART interfaces
- IR interface, I<sup>2</sup>C interface, SSP master interface, and GPIO interface
- Eight PWM interfaces (four independent interfaces and four ones multiplexed with other pins)
- Two SD 3.0/SDIO 3.0 interfaces, supporting SDXC
- One USB 3.0/USB 2.0 host/device port
- One PCIe 2.0 interface in master/slave mode

- SLC or MLC
- 4-/8-/24-/40-/64-bit ECC
- Components with 8 GB or larger capacity
- Booting from the SPI NOR flash, SPI NAND flash, or NAND flash
- Booting from an eMMC or PCIe

### External Memory Interfaces

- DDR4/DDR3/DDR3L/LPDDR3 interface
  - 32-bit LPDDR3
  - 32-bit DDR4/DDR3/DDR3L
  - Maximum capacity of 1024 MB for a 16-bit DDR SDRAM
  - Maximum total capacity of 2048 MB for two 16-bit DDR SDRAMs
- SPI NOR flash interface
  - 1-/2-/4-line mode
  - 3-byte or 4-byte address mode
  - Maximum capacity of 32 MB
- SPI NAND flash interface
  - Maximum capacity of 512 MB
- eMMC 5.0 interface
  - Maximum capacity of 2 TB
- NAND flash interface
  - 8-bit data width

### SDK

- Dedicated SDK for the consumer mobile camera
- High-performance H.265 iOS/Android decoding library

### Physical Specifications

- Power consumption
  - Typical power consumption of 1 W
  - Multi-level power saving mode
- Operating voltages
  - 0.9 V core voltage
  - 3.3 V I/O voltage and 3.8 V margin voltage
  - 1.2 V, 1.5 V, 1.35 V, and 1.2 V voltage for the DDR4, DDR3, DDR3L, and LPDDR3 SDRAM interface, respectively
- Package
  - RoHS, FC-CSP
  - Body size of 10 mm x 10 mm (0.39 in. x 0.39 in.)
  - Lead pitch of 0.4 mm (0.02 in.)

## Functional Block Diagram

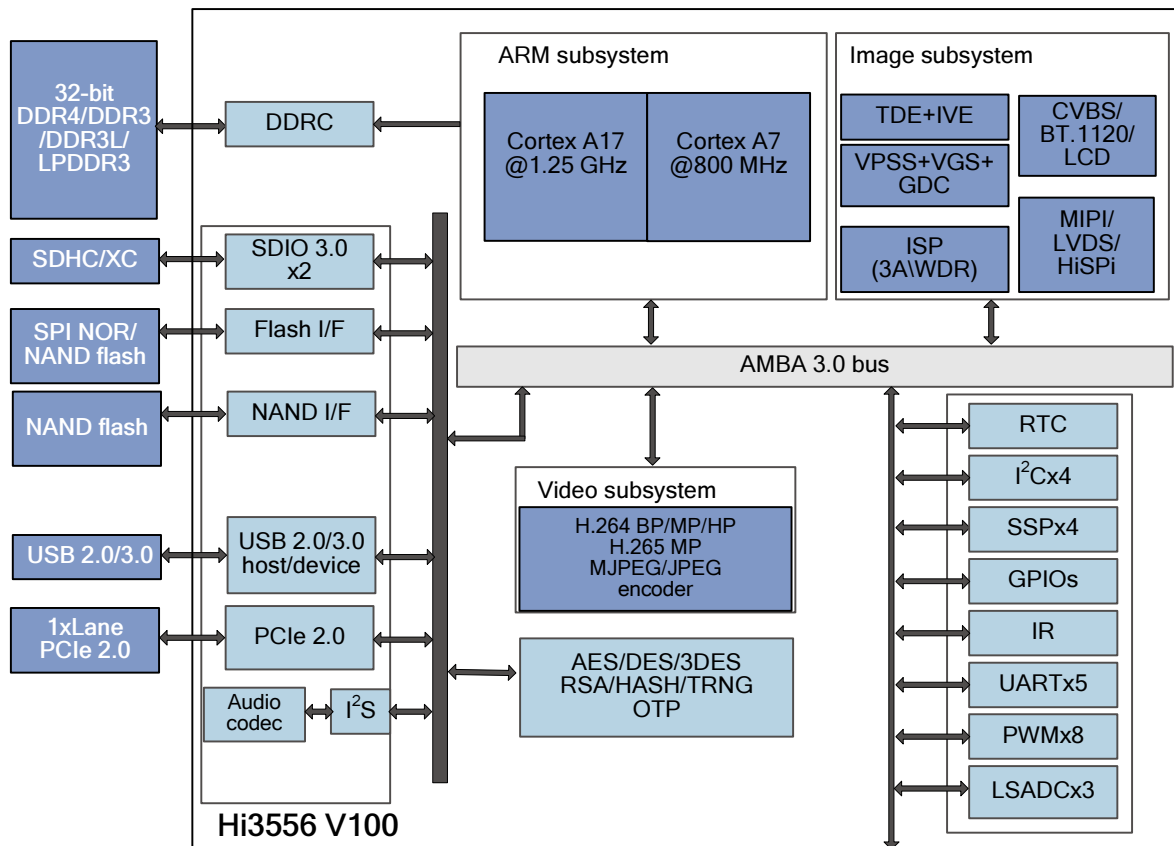



# Hi3556 V100 HD Mobile Camera SoC

## Hi3556 V100 Motion Camera and Professional Camera Solution

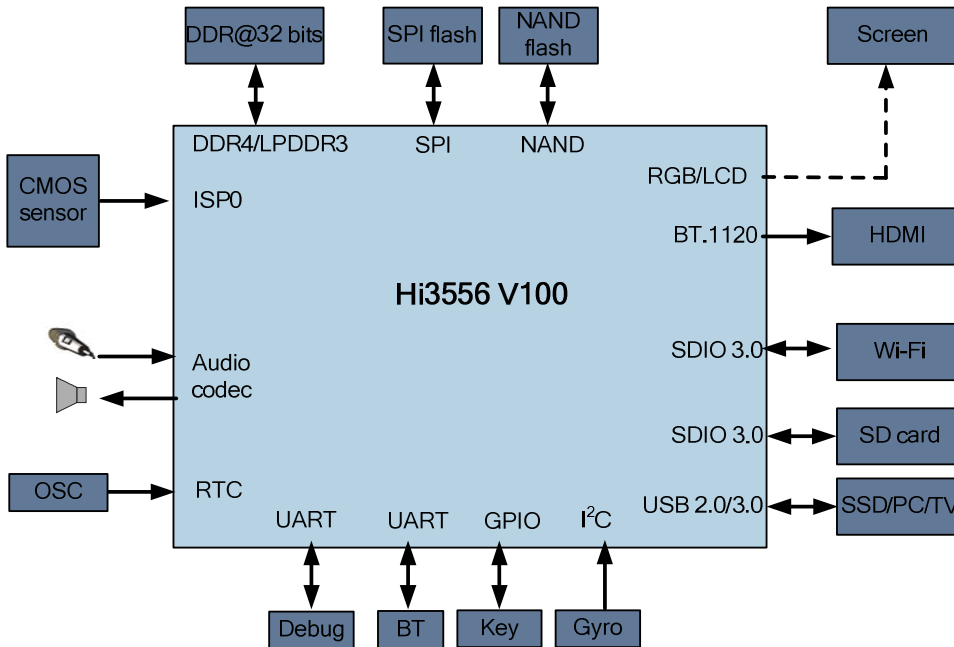

- Supports 6-DOF DIS for the 1440P30 or 1080P60 video.
- Supports HDR photographing.
- Supports RAW video output.
- Support low-power LPDDR3 and DDR4.
- Supports 2x SDIO 3.0, the extended low-power Wi-Fi module, and the external SDXC card.
- Supports dual MICs and provides advanced dual-MIC NR algorithms.

## Hi3556 V100 3D/VR Camera Solution

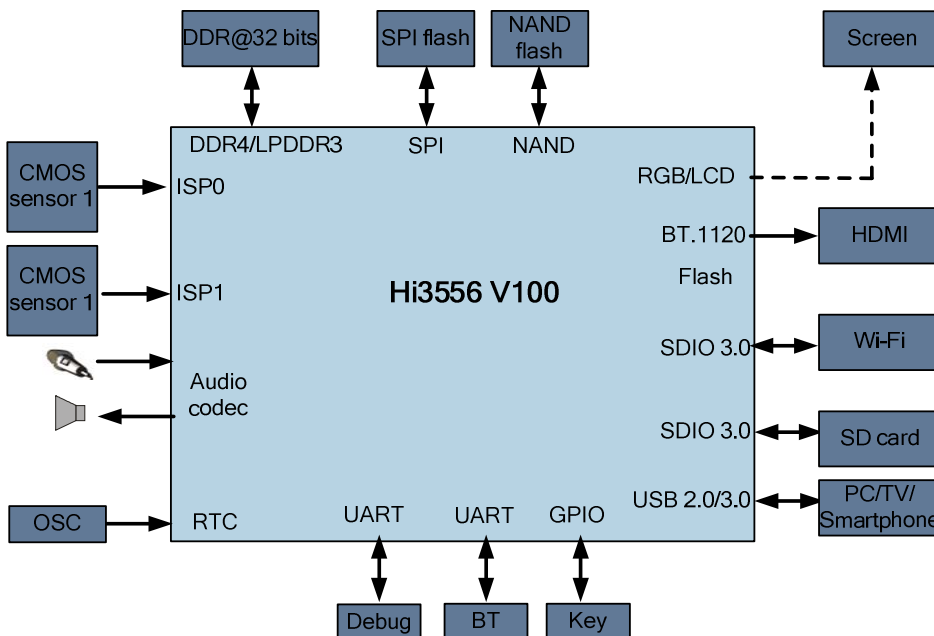

- Supports dual-sensor inputs and dual-ISP processing.
- Supports HDR photographing.
- Support low-power LPDDR3 and DDR4.
- Supports 2x SDIO 3.0, the extended low-power Wi-Fi module, and the external SDXC card.
- Supports dual MICs and provides advanced dual-MIC NR algorithms.



# Hi3556 V100 HD Mobile Camera SoC

## Hi3556 V100 Drone Camera Solution

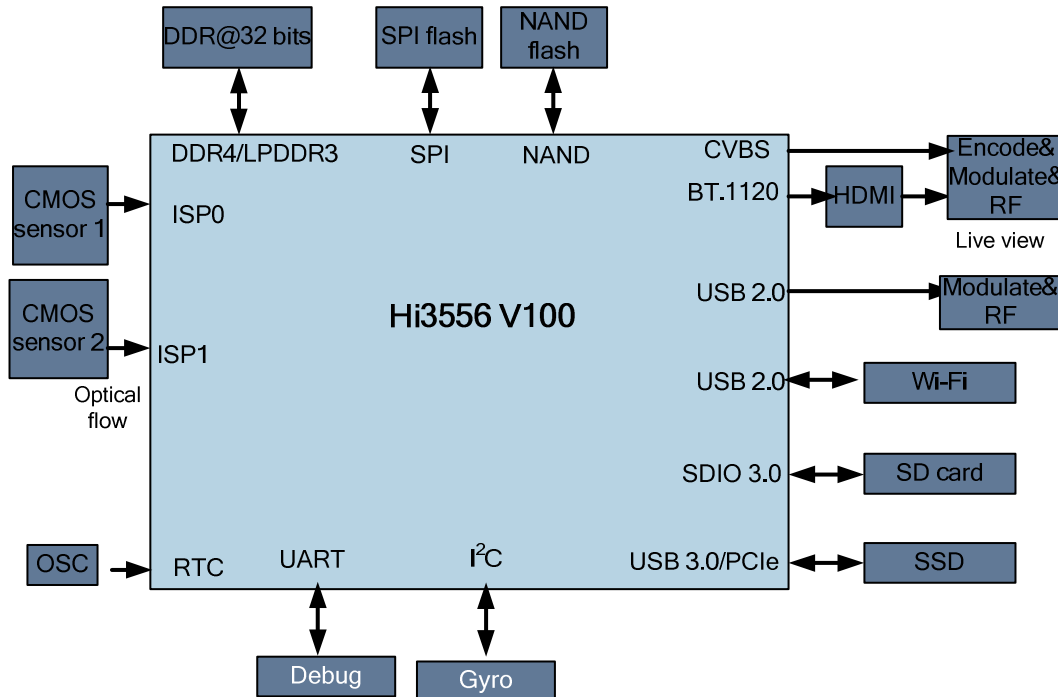

- Supports 6-DOF DIS for the 1440P30 or 1080P60 video in the gyro auxiliary information.
- Supports HDR photographing.
- Supports RAW video output.
- Support low-power LPDDR3 and DDR4.
- Support the input of the second-channel sensor for optical flow hovering.
- Support low-power LPDDR3 and DDR4.
- Supports CVBS-to-HDMI or BT.1120-to-HDMI and outputs videos in real time for picture transmission.
- Allows the second-channel low-delay stream to be output over the USB 2.0 port for picture transmission.